

# PARADIGM SHIFTS IN THE STUDY OF FERTILITY BEHAVIOUR

Moumita Basu\*

And

Jeetendra D. Soni\*

## Abstract

The conceptualization of the study of fertility behaviour started in late 18<sup>th</sup> century but the issue gained prominence only in the second half on the last century. In this paper an attempt has been to synchronize all the important efforts made in this line right from the simplified classical theories to highly complex analytical frameworks of recent times. It is to explain the changing paradigms in the course of study of the concerned subject.

Along with these theoretical frameworks, deterministic models are also made to evaluate the fertility behaviour. In the current analysis shifting nature of examining this issue is dealt with. Here a clear shift is perceived from a mere socio-economic perspective to a multifaceted combination of social, economic, cultural and psychological approaches to have a better understanding in the fertility behaviour.

## CHANGING PARADIGMS IN THE CONCEPTIAL FRAMEWORKS:

In the historical past various attempts have been made to provide insight and solutions to the issues related to the problems of population growth and understanding the fertility behaviour. Efforts to make a concrete explanation for these social phenomenon are still going on. It is very essential to have a deep understanding that how the issue of population growth and fertility behaviour have been conceptualized over a period of time. Many economists, sociologists, psychologists, population scientists and others have contributed in this field to find out that, what are the different attributes which have association with fertility behaviour and how these attributes are responsible in determining or controlling the fertility behaviour of a society. Some of them are discussed in the following discussion.

The classical economists (excluding Malthus) writing on the stationary state gave a hazy picture of the effects of the population growth. According to them the stationary state is reached when the economy has fully adopted new technological possibilities or choices. In this stage economy has attained its maximum per capita income. In the absence of new

---

\*Both are PhD. Research Scholars in Centre for the Study of Regional Development, Jawaharlal Nehru University, New Delhi, 110067, India.

Jeetendra D. Soni, # 208, Periyar Hostel, J.N.U., New Delhi, 110067, India. Ph. No.-919868045152

Moumita Basu, # 111, Block no. III, Yamuna Hostel, J.N.U., New Delhi, 110067, India. Ph. No.-919818064779

technological choices, more demand for food with fixed land resources ultimately lead to lowering the per capita income. Thus the population growth is having inverse effect.

Adam Smith having more optimistic view regarded the growing population as the main spring of development under the assumption of ever increasing returns to labour. Adam Smith contended that an ever-expanding population would widen the scope of the market thereby enhancing division of labour and specialization of economic activities and thus generating greater output (Ojo, 1980).

Robert Malthus gave his pessimistic view in his essay on the principle of population (1789) based on the law of diminishing returns to land. He postulated that while population grows at a Geometric progression, food production grew at the Arithmetic progression. According to him therefore there is a competition between population growth and food production where the population surpasses food production. So if population growth is not controlled it would lower the per capita income to a subsistence level. He asserted that if voluntary checks are not followed natural calamities such as pestilence, war, and misery would act as a restraint to population growth.

In the same stream of thought Ricardo argued that the population growth would result in a steady decline of per capita income, which would consequently lead to a stationary state.

Karl Marx disagreed with Malthus and Ricardo and argued that the population problem was an off spring of the capitalist mode of development. He therefore, said with the proper management of population growth, it could serve as an asset for the well being of a nation. In 19<sup>th</sup> century French sociologist, Dumont had argued that people like to move up along the social ladder and this is usually possible in small families. He induced that people should restrict their family size. In the beginning of 20<sup>th</sup> century another sociologist and demographer, Kinsley Davis had argued that every change brings multiple responses, such as change in mortality in terms of decline in mortality rate brings consequent responses on population growth, age at marriage, contraception prevalence rate, migration etc.

These classicists were criticized for lacking in their fore sight in terms of technological development and the discovery of new lands. In Europe, application of Malthus theory failed as per capita income rose with rapid population growth. While the above theories relate population to economic indicators but none of these tried to explain the process of population growth and its impact on development.

The demographic transition model was an attempt to explain the historical process of the population growth of developed countries. This theory postulated that during the process of modernization first decline in mortality is experienced and followed by a fall in fertility. During the intervening period, population explosion takes place largely due to the natural growth. This theory divides developmental processes into four phases – the pre modern, early transition, late transition and modern phase.

In the pre-modern phase both birth and death rates are relatively high and population is in high stationary stage. In the early transition, death rates fall sharply due to the application of modern medicine, improved sanitation and poverty reduction, while birth rates remain unchanged. It is followed by late transition, in which, fertility finally succumbs to the allurements that accompany modernization. Increasing female literacy and participation in economic activities, reduction in infant mortality, traditional belief loosened, betterment of health infrastructure, increase in social security also worked considerably in fertility reduction. With the sharp reduction in fertility rates, mortality was also continuously declining and population growth retards. In the last phase both fertility and mortality have fallen to very low levels and population attains a low stationary state. The theory was also criticized on various grounds like, it does not have predicting values, seems like a grand historical generalization and even the experiences of various developed European countries were not consistent

Demographers and sociologists have been working in this field from quite long, and the efforts of economists in this field in 1960's and 70's have appeared as innocent beginning among the developed communities. But the former were neither systematic and coherent, nor general in their pieces of knowledge.

Micro economic theories of fertility, developed by economists, focus on ultimate decision maker, advances explanations of the effect of socio-economic development on changing fertility in any micro region. These theories have their limitations as well as sound aspects and each of them provide significant insight into the relationship of fertility and its determinants. The cost benefit analysis is the basis for all the economic theories of fertility, where the importance of perceived benefits (utilities) and costs (disutilities) consideration in reproductive decision-making is identified.

The basic assumption in economic theories of fertility is that the reproductive decisions in developing countries are rational. A woman, in the absence of breast feeding,

has potential of producing 15 children in their reproductive span, since a woman no where produce so many children. The choice making is obviously involved (Alexander, 1988). According to A.J. Coale (1973) one of the precondition of fertility transition is that the reproductive decisions must be with in the calculus of conscious choice. The change in mentality that leads to family limitation includes a clear notion of what family size ought to be.

In 1957, Leibenstein in his economic theory of fertility has hypothesized that fertility decline take place in the course of growth in per capita income. He assumed that families would balance utilities against disutilities, related to  $n^{\text{th}}$  child in order to determine whether a family wanted an  $n^{\text{th}}$  child. So here he gave an importance to rational decision for marginal child. He mentioned three types of utilities, such as, consumption, production and security utility and two types of disutilities, such as, direct costs for feeding a child and indirect costs as losing opportunities for better earning. He believed that utilities always decrease (except consumption utility) with higher birth order but disutilities do not give a clear picture. Gary Becker, who belongs from Chicago school, also favoured this type of explanations in his paper, published in 1960's. He favoured strong interlinkages between economic development and fertility reduction. To explain fertility he used Hicksian's version of micro consumption theory and developed a demand theory as a pioneering work in this field. He argued that children should be viewed the same as the household views the purchase of durable goods. He studied the American society to explore that why richer families prefer small family size. He found that the children are not inferior goods and as income rises, parents aspire to improve the quality of investment on each existing children. This was a good attempt, which created an intellectual climate in which a good deal of theoretical and empirical research could be done.

Further Namboodari modified the Becker's concept and said that decision regarding to the family size is taken on the basis of past experience initially after having the first children. He further added that tastes also changes during this gap between the present and next order children.

In the similar line of argument other contributors also had given an importance to cost of time and changing opportunity cost of mother due to educational attainment along with income, to strength price effect argument. Becker also gave such explanations in his later work in 1991 and argued that, as the opportunity cost of mother's time increases, say by

increase in the labour force participation by married women, raises the cost of additional child care. Further researchers thought that the quality and opportunity cost price effects need not be substitutes, they may be additive. In the coming period they thought in the track of the relative time costs on commodity consumption, compared to 'child services' consumption because with higher income scale goods take more time to consume, which competes with time for 'child services'.

On the other side T. Paul Schultz's (1969) work, on infant mortality, suggested that household desire a target number of surviving children. As income increases the possibility of survival also increases and because of this few births are desired to get the target number of children and also number of son.

Some sociologists, economists and demographers have emphasized the effect of socio-economic status on the taste for children, or the preferences for the material goods or relation between these two. Few of them thought about the threshold values of income, education and economic and social development and believed that prior to the threshold value there is a positive relation between income and above two variables. With these developments in 1970's the great debate on population policy started, which emphasized on the polarization of the views into two opposite directions. On one side of the argument economists and sociologists were with the view that 'development is the best contraceptive' where the family planning programs have little bearing in bringing about changes in fertility behaviour. And they assumed that as society develops, fertility reduction take place because of the changes in demand for children. On the other side proponents of family planning programmes had pointed out to the large unmet need for contraception and the high level of unwanted fertility that could be reduced by strengthening the family planning programmes.

The trends of fertility decline have been extensively documented and analyzed by increasingly sophisticated methods in the last quarter of 20<sup>th</sup> century, but the great debate continues. Only slight progress has been made towards a consensus that both views are at least partially valid. Many researches have perceived declining fertility as a complex process that involves both, the changing demand for children as well as changing attitudes towards family planning programmes. Among the numerous efforts, which were taken with combination of both the views, Easterline's work was most popular.

Easterline have come out with a series of papers in 1960's and 1970's, to address the basic framework of demand and potential supply of children, and developed the supply-

demand theory. He stated that, initially when the level of development is low, demand for children exceeds potential supply because of high child mortality rates (CMR) and the situation of deficit supply takes place. But with the time when the increasing level of development reduces CMR, potential supply increases and after a critical point it overtakes the demand for children and the age of excess supply starts. Further with increasing level of development, means of fertility regulation become socially acceptable and then after a period of time the stage of equilibrium would establish. Easterlin also mentioned that the effect of income also affects tastes, preferences and norms for the disposal of income. He further stated that increased income raises the relative desire for material goods and consequently lower fertility substantially. It is the most widely used theory, because it is conceptually simple and at the same time powerful in explaining fertility behaviour. It synthesizes both economic and sociological approaches to the analysis of fertility. While the economists have stressed on the demand side arguments, sociologists have explored the supply side factors of the fertility differences among different societies. Among the supply side factors, those well recognized are the IMR, the female age at marriage, duration of lactation, birth interval, mother and child health care etc. these variables are identified as important intermediate variables following the proximate determinant analysis, (Bongaarts, 1978).

Caldwell (1970), in his work “Treaties of the Family” explained the fertility behaviour in terms of intergenerational wealth flow at the societal level. He explained that, in the societies where children spend more on their parents after growing up in comparison to what their parents spent on them, generally have high fertility. On the other hand if the flow of wealth is opposite or in the direction from the parents to children as find in modern societies, then in these societies fertility rate has to be lower than the previous societies.

On the basis of the empirical study of English middle class, Bank has found that to maintain ‘target standard of living’ people cut back their fertility. Duesenberry and Okum argued that varied socio-economic groups establish different social conventions and then conform to a very high degree of the extent to which expenditure can be varied and determine the desired number of children, (from Leibenstein, Harvey, 1974)

Later on in 1970’s Leibenstein has found that quality of children, in countries, where state take responsibility of children’s education and other facilities, this cost is unlikely to be a significant deterrent in terms direct cost of children for fertility control. At the same time, value of mother’s time is highly cultural bound rather than household income, so mothers

time is also not significant here. Women's education also has an impact on taste rather than on value of time.

To come out from the above limitations, he gave a more adequate theory on fertility and argued that, income differential with increasing socio-economic status are much more significant than the increase in the costs of children because costs of child rearing need not increase proportionately with increase in income. As Kuznets has concluded that normal interpretation of fertility behaviour and costs influence does not appear sufficient, a social standard influence group theory of cost pressures enables us to workout an explicit explanation. At the same time, social and economic influences must not be considered in isolation because the economic changes always influences the social status of families, and later on tastes change regarding children and goods that compete from one another. So in high status household it may become necessary to spend more on target commodities to maintain their status membership and in this class family member demands more in terms of commitments. This results into tastes differences of people in different classes, which gets influenced by the occupation and education of the group members. Therefore it is possible that households in higher income group would have few children than the low-income group households.

Blake (1968), Lesthage (1983) and Preston (1987) stressed on the role of norms in determining the fertility behaviour. How do norms effect individual's decision to have children? In the societies such as the Catholic Church norms of fertility are motivated by the fear of sanctions. Norms which usually stands in opposition to desires, wishes, preferences and drives, allow groups to solve dilemmas of cooperation that flow the egoistic motivations of their members, (Friedman and Weingast, 1993). Some authors have suggested that cultural and ideological climate can produce similar effect, presumably in essence of sanctions. But there are some problems like these norms are not well defined, potentially relevant alternative causes often are not controlled, mechanism of fertility changes due to ideological changes is not defined.

Because of above lacunas, in the last quarter of 20<sup>th</sup> century, rational choice modals have become increasingly prominent in fertility research. These are based on constraints and values where former refer to conditions external to individual and later refer to inner state that enable people to evaluate the consequences of desirable behaviours. But the problem is the unobservability of values, which are subjective constructs. So the rational choice theories

usually specify values by assumptions rather than by imputation (H. Simon, 1986; Stigler and Becker, 1977).

Cleland (1987) has given an iconoclastic view of the fertility behaviour after attacking on the traditional believes of fertility theories. He criticized demand theories and argued that, even in societies where children are not costly people are adopting fertility regulation methods as found in Europe. He said that, people adopt fertility regulation behaviour to see the others or through the diffusion of innovative ideas. Further he found that upper classes welcome the innovative behaviour first and bring ideational changes and then it spreads in the other social groups. The speed of the diffusion of innovation depends on the efficiency of communication network.

In another explanation theorists said that, there should be a threshold level of development to experience decline in fertility behaviour. Kirk and Srikantan have worked on joint threshold, a combination of various indicators of development to decide the lower limit of the level of development and to experience the decline in fertility. Caldwell argued that the threshold level vary region to region, country to country for instance threshold level in Asian countries is lower in comparison to African countries.

Bongaarts, Warkins and some other researchers have argued that with the changes in time threshold also changes. As the time passes the communication net become strengthened and taste changes and due to this fertility rates decline at the lower level of development in comparison to past.

Walle (1992) has stated that a fertility decline is not very far away, when people start conceptualizing their family size and it cannot take place without such conceptualization. Further population has now become numerate about children; the event is interesting only in retrospect and has little bearing on the future.

Friedman, Hechter and Kanazowa (1994), have proposed a theory of the value of children, to built on existing rational choice modals of fertility by specifying a new assumption of common immanent values to supplement the more familiar instrumental values. They used the assumption of uncertainty reduction to explain why some people in advanced societies have no children while others have at least one child. They argued that in traditional circumstances children were doubly important for uncertainty reduction both in terms of their ability to provide wealth and insurance for their ageing parents and for their contribution to social integration. The first set of contributions diminished in value over time



but not the second. The temporal shift in the value of children suggests, as does, the economic theories of fertility decline, that the number of children demanded should reduce but not to zero.

However, the critical question how much of fertility change in a particular society can be attributed to each of these broad explanatory factors, such as socio-economic development and diffusion of family planning programmes, remains unanswered. Along with the process through which social and economic variables affect fertility and its proximate determinants have received relatively little attention. Bongaarts in 1993 have attempted to address this problem by proposing a variant of Easterlin's model. The variant allows the convenient quantification of the three key mediating variables: the supply of and demand for births, and the degree of implementation of reproductive preferences. He also proposed a new technique to trace the fertility trend in terms of the separate effects attributable to the individual mediating variables. In the application of this model, he found that increase in preference implementation are on an average slightly more important determinants of fertility decline than changes in wanted fertility.

In the study of effects of development and family planning programmes on the mediating variables, he found that socio-economic development has the expected negative effect on wanted fertility as well as a positive on implementation of preferences. Family planning programmes exert their strongest effect by increasing the level of implementation, and also have influence on wanted fertility.

Caroline Foster (2000) has propounded "A Biosocial Approach" to limits the low fertility. She acknowledged that our biological predisposition towards nurturing behaviour plays an important role in the motivation for child bearing dose not mean that all women are genetically determinant to become mother i.e. biology is not destiny. In the second half of 20<sup>th</sup> century the link between biology and destiny also broke with use of efficient contraceptives and induced abortion. What remains is the knowledge that to a greater extent, we all have a need to nurture and in turn be nurtured that is the manifest characteristic of only evolved human psychology. It is evident that despite of the high costs and greater difficulties of bearing and bringing up children and in the absence of social force most women will choose to have at least one child. There is no inevitable link between genetic disposition and behaviour therefore it is possible that predisposition towards nurturing could be supposed,

resulting in further fall in fertility rates that is why women will continue to fulfill this fundamental human need by having children.

In the above mentioned discussion, it is very much clear that social and economic status, socio-religious norms, cultural practices and psychological mindset have played a prominent role in changing fertility behaviour. But still none of the theoretical explanation alone is able to give a complete explanation of this complex human behaviour in its entirety. Endeavors are still going on in this field to formulate a more acceptable and realistic explanation of this behaviour. So we have to take a comprehensive approach to deal with this subject to have a more pragmatic picture of this concerned phenomenon.

### **3.2 DETERMINISTIC MODELS:**

In the area of the study of fertility behaviour scholars from the various fields of the knowledge came forward with different type of models, which are deterministic in nature. In these models an attempt has been made to streamline the interrelationship between fertility behaviour and its determinants. Such type of modeling includes, in what way various social, economic, psychological and demographic aspects are associated with fertility behaviour and among themselves. These models also deal with the direction in which these variables are operating to have an impact on fertility behaviour. In the following discussion it has been discussed that how these relationships have changed in terms of direction and nature of variables over a period of time.

Though the birth of a child is basically a biological phenomenon, but child bearing takes place in a particular social set-up, it is affected by social, cultural and economic factors. So the conception of baby is affected by the social set up of that particular society, such as its customs, structure, norms and value system related to the various aspects of the childbirth. So it can be said that, the social environment, in which people live, which comprises various political and economic settings, regulates fertility behaviour of its inhabitants. Along with the societal effects on child bearing, decisions of individual couples about whether to have a child or not also have significant influence. Therefore to have a deep insight into the issue of differential fertility one has to have a clear idea about the relationship between the independent variables for instance social, economic and demographic variables and fertility behaviour.

Kingsley Davis and Judith Blake (1956) have explained the way in which all non-psychological factors affect fertility in any society, in their work “Social Structure and Fertility”. They gave eleven intermediate variables, for three stages of child bearing, through which non-psychological factors affect fertility behaviour. All the eleven intermediate variables have either a positive or negative effect on fertility. These are as follows:

#### INTERMEDIATE VARIABLES

##### I Intercourse Variables:

(A) Those governing the formation and dissolution of unions in the reproductive period.

- (1) Age of entry into sexual unions.
- (2) Permanent celibacy.
- (3) Part of the reproductive period spent after or between unions
  - a) When unions are broken by divorce, separation or desertion;
  - b) When unions are broken by death of husband

(B) Factors governing exposure to intercourse within unions.

- (4) Voluntary abstinence.
- (5) Involuntary abstinence.
- (6) Coital frequency.

##### II Conception Variables:

- (7) Fecundity or infecundity, as affected by involuntary causes.
- (8) Use or non-use of contraception
  - a). By mechanical or chemical means;
  - b). By other means.
- (9) Fecundity or infecundity as affected by voluntary causes (sterilisation, sub-incision, medical treatment, etc.)

##### III Gestation Variables:

- (10) Foetal mortality from involuntary causes.
- (11) Foetal mortality from voluntary causes.

All of these variables are present in every society and any change in fertility may be affected through change in one or more of these intermediate variables.

Freedman (1962) has made modifications in the above model by including a set of variables like education, occupation, income, family structure etc.

Yankey (1969) presented a model, which explains the taxonomy of fertility determinants. He gave three individual classes of his model.

Class 'A' includes the norms regarding family size and intermediate variables, Class 'B' incorporate intermediate variables and Class 'C' includes the dependent variables.

He has argued that most of the population scientists, especially, fertility researches focused on the relationship between the Class 'A' and Class 'C' variables. He said that there is a need to look into the interrelationship between Class 'A' and Class 'B' variables and between Class 'B' and Class 'C' variables.

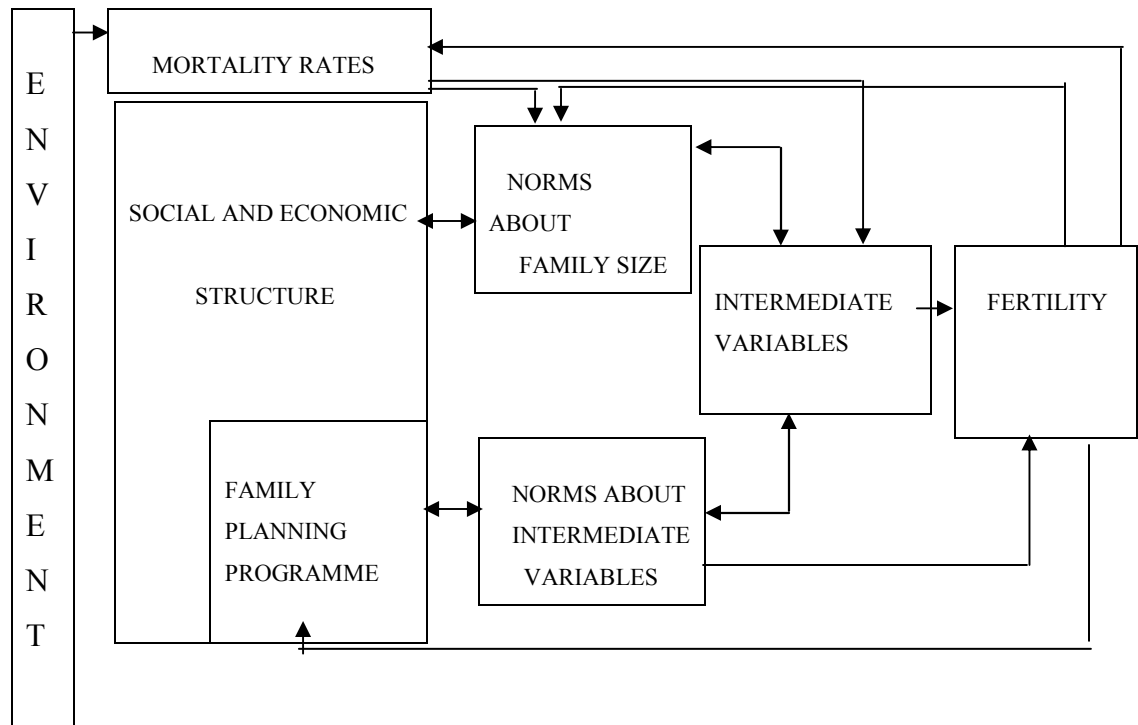

FIG. NO. 3.1  
YANKEY'S MODEL (1969)

In the similar path an important contribution came from Bongaarts in 1978, who tried to make quantitative assessment of the effects of intermediate variables on fertility. He effectively simplified the relationship fertility and its determinants, which can be presented in following diagrammatic form.

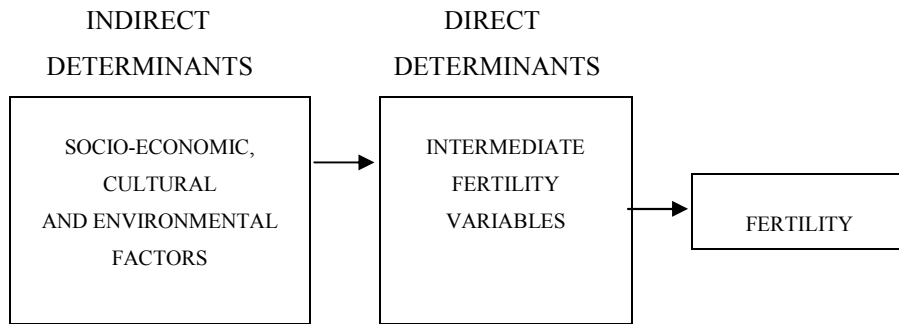

FIG. NO. 3.2  
BONGAARTS'S MODEL (1978)

Bongaarts in his empirical research found that a major portion in the change in fertility levels could be explained by only four intermediate variables out of eleven intermediate variables. These variables are called proximate determinants of fertility. The details are as follows:

- (1) Nuptility variable (age at marriage and proportion of non-marriages).
- (2) Period of lactation following childbirth.
- (3) Incidence foetal wastage.
- (4) Prevalence of contraceptive practice.

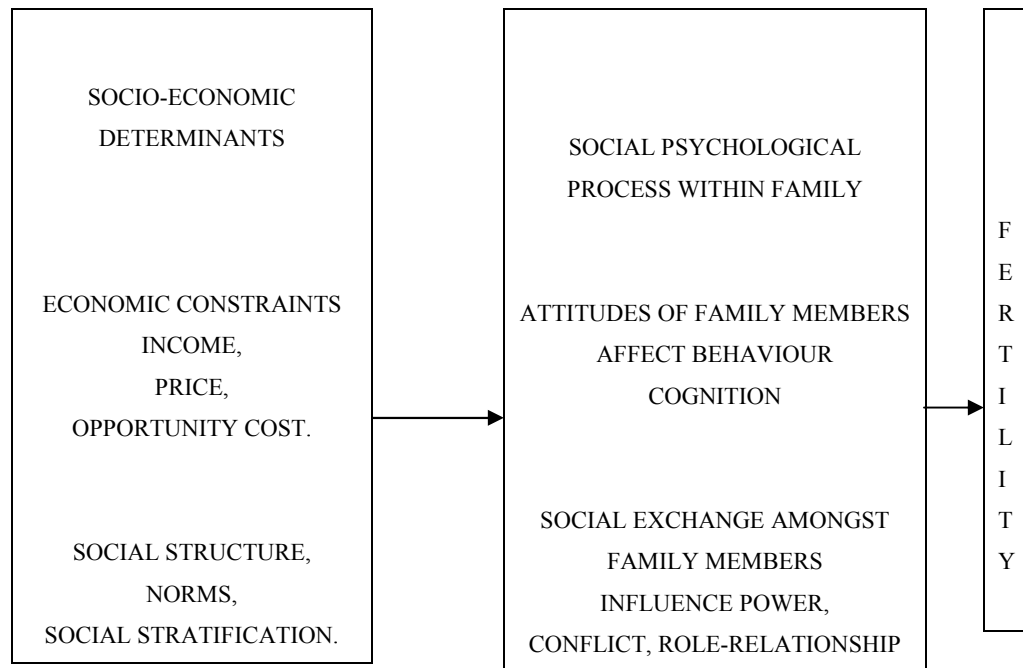

FIG. NO. 3.3  
RECHARD, BAGOZZI AND LOO (1978)

Richard P. Bagozzi and M. Frances Von Loo (1978) developed a general fertility theory and hypothesized that demand for children is primarily determined by social psychological process with in the family, subject to certain socio-economic constraints. They proposed two social psychological processes as determinants of fertility. First, the attitude or tastes of family members influence the demand for children. Second, the nature of the husband-wife interaction (in terms of sharing of power, conflict, decision making process and marital satisfaction) decides family size. They mentioned that the socio-economic factors influence fertility through their impact on social psychological processes within family, which then direct influence the fertility behaviour.

T. R. Balakrishnan, G. E. Embanks and G. F. Grindstaff (1980) have studied the influence of socio-economic and demographic variables on fertility. They also tried to prepare a model to explain the relationship between fertility and its socio-economic and demographic determinants. They took religion, ethnicity, mother tongue and residence as inherent characteristics, education, income and work status as achieved characteristics. The current age of women and age at first birth are incorporated as demographic factors in their model to explain fertility behaviour.

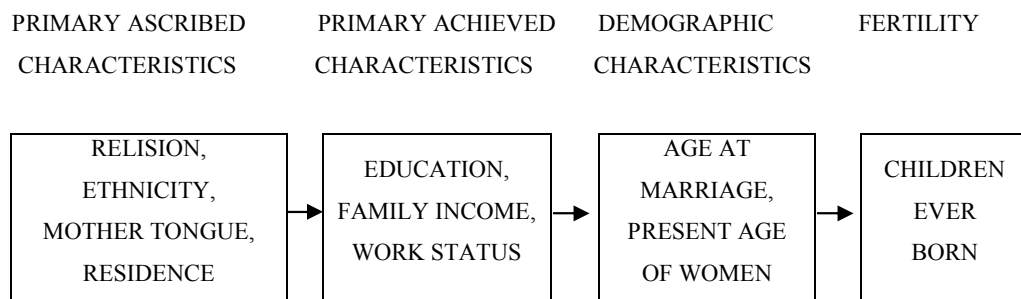

FIG. NO. 3.4  
BALAKRISHNAN, AMBANKS AND GRINDSTAFF (1980)

Kenneth C. W. and Helon L. Ginin (1988) have proposed a model for the analysis of fertility behaviour in which the process of family formation in modern world has explained. According to them fertility behaviour is not always a result of decisions at conscious level and it certainly act at a given time frame. These decisions are not always rational ones, but some of these are made rationally where people weight alternatives and make decisions to fulfill their needs or objectives at the best. They said that a decision to have a child or not, is

not a decision of a single occasion. The ultimate decision regarding family size is the result of a series of minor decisions.

Before the analysis of their framework one should know the inherent meaning of terms like “cultural press” and “situationally specific factor”. Cultural press comprises all the institutional and cultural support for child bearing. It is a set of values in favour of having children. Where the later includes the factors, which mold couple to have more children and the factors, which stop them for having more children. The term “Situationally Specific Factors” refers to the conscious and explicit reasons for having a child or not, in favour of couples decision, at any particular time.

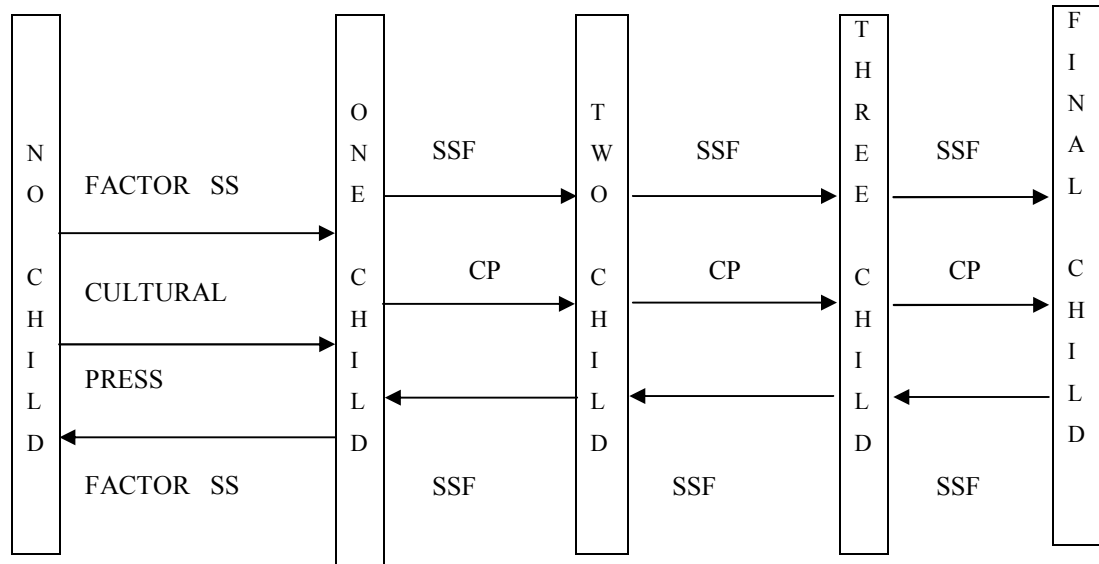

FIG. NO 3.5  
KENNITH, KAMMEGER AND GININ (1988)

Premi (2002) has found that the capacity to reproduce is governed by several parameters. These parameters are gene selection, age at menarche and age at marriage, length of lactation period, natural sterility, contraceptive use etc. The socio-economic status of any community has control over these parameters, which determine the fertility behaviour of that particular society.

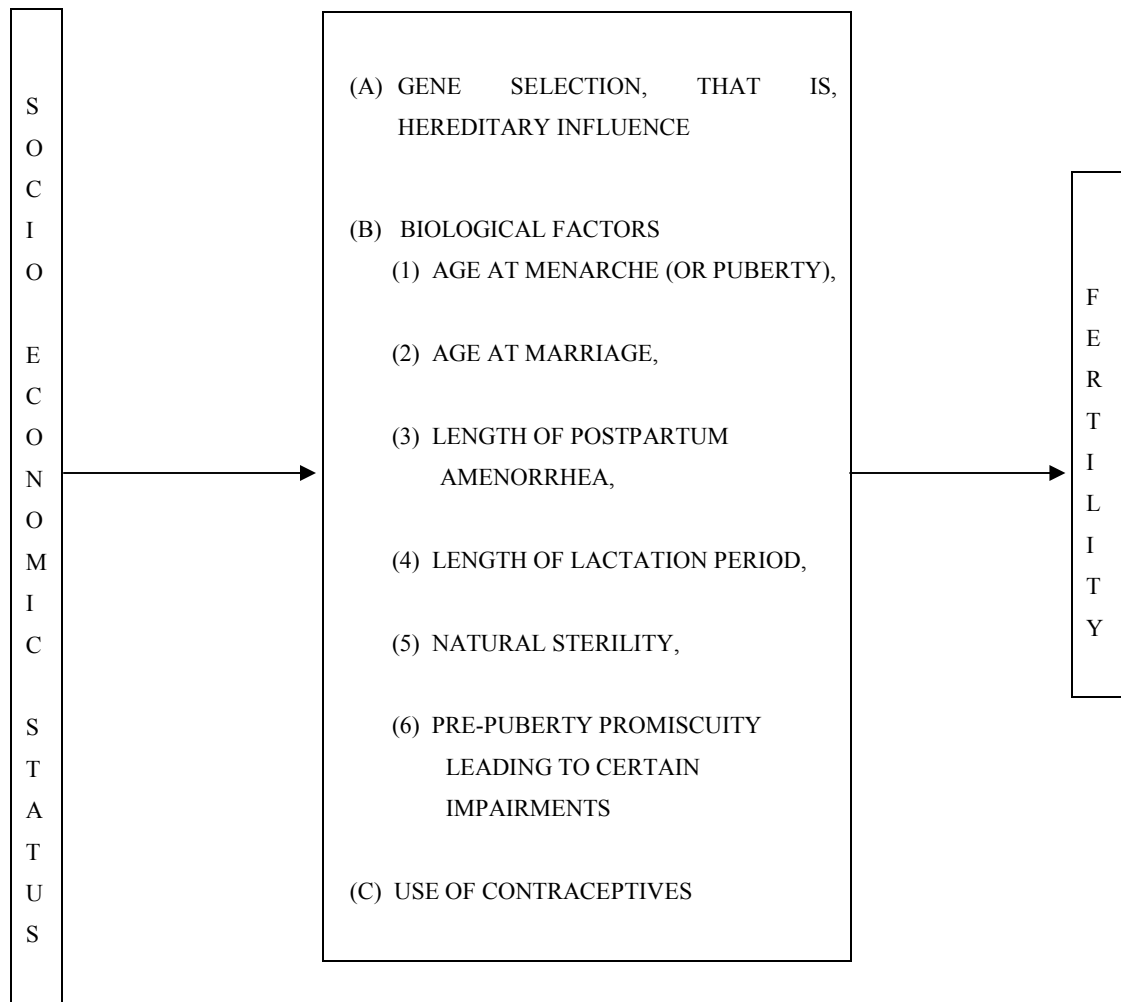

FIG. NO. 3.6  
PREMI (2002)

All the deterministic models try to give a simplistic explanation of the association between fertility behaviour and its determinants same as examples, which are discussed above. Same as conceptual frameworks, there is no single model, which provides all the dimensions of the issue under consideration. Efforts are still going on in this direction to draw a more generalized and acceptable models.

Fertility behaviour is a dynamic phenomenon and with changing nature and structure of society the approach to study this behaviour should also incorporate the emerging issues, which have potential to affect the fertility behaviour. So here it is very much clear that there is no static explanatory framework to study this phenomenon and with the evolution of the society these approaches will also change. Thus, this area is having great potential of research in the future.



